



Work Station Assembly

Description

We are a UK designer and manufacturer of ruggedised keyboards, tracker balls, PC's and display products.

The Work station assembly has been designed to be used in industrial environments.

Its tough stainless steel finish makes it ideal for harsh applications and suitable for wash down areas.

It allows for our standard stainless steel **ClientPC**, **ThinClient** or **SlimMonitors** to be assembled together with either a stainless steel **96T** or **128T** keyboard to either a sturdy wall or our own stainless steel floor mount pedestal.

Desk mount brackets are also available.

Features

- Built in Watchdog
- High IP & NEMA sealing
- Rugged Stainless steel construction
- 75mm VESA wall mounting brackets
- Fits **ClientPC** / **ThinClient** / **SlimMonitor**
- Fits **96T** / **128T** keyboard
- 2M high stainless steel pedestal
- CKS designed & manufactured



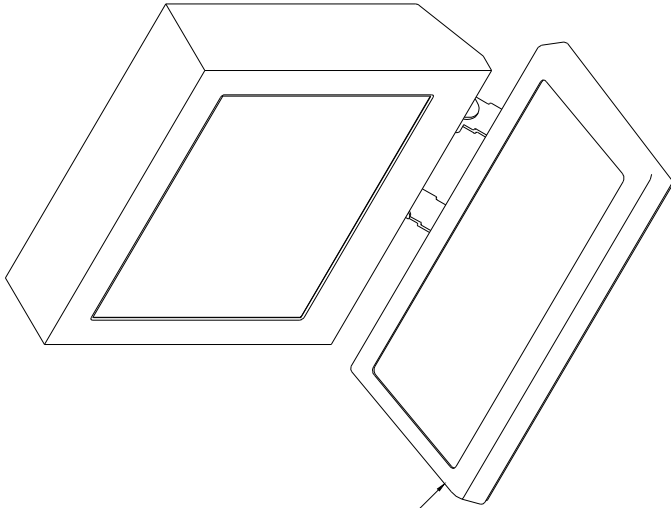

NOTE- KEYBOARD 125T

